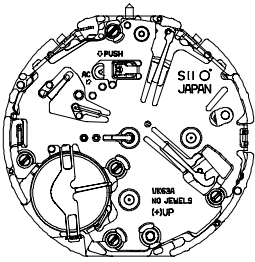
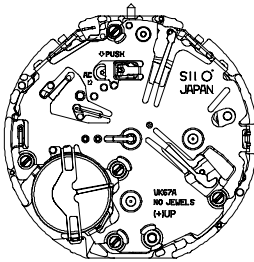
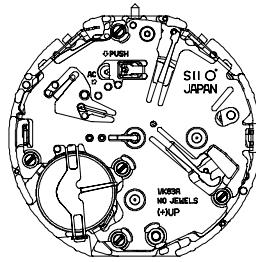
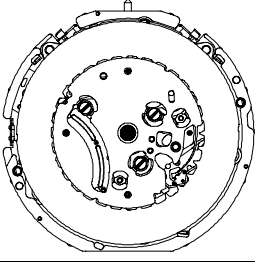
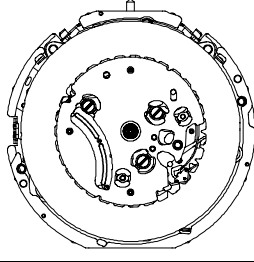
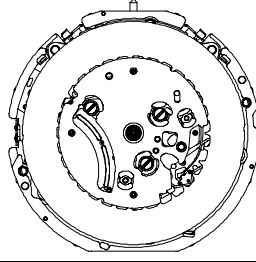

**TECHNICAL GUIDE
&
PARTS CATALOGUE**

Cal.VK Series

ANALOGUE QUARTZ

SII Products

Item		Cal. No.	VK63	VK67	VK83
Movement					
					
Movement size	Outside diameter	φ 30.80 mm × 29.10 mm (3H - 9H)			
	Casing diameter	φ 29.00 mm			
	Total height	5.10 mm			
Time indication	2Hands (hour , minute)	○	○	○	
	Date Calendar	○	○	○	
	Small second hand (6H)	○	○	○	
	Center chronograph (1/5 second)	○	○	○	
	60 minutes counter (12H)	-	○	-	
	60 minutes counter (9H)	○	-	-	
	20 minutes counter (9H)	-	-	○	
	12 hours counter (9H)	-	○	-	
24 hour indicator (3H)	○	-	○		
Driving System	Two pole stepping motor Step motor 2 pieces				
Additional mechanism	Date display with quick correction Electronic circuit reset switch Time setting with stop-second				
Accuracy	Less than ± 20seconds : Monthly rate at normal temperature range				
Battery	SR936SW (Silver oxide battery) Battery life is approximately 3 years (60 minutes chronograph operation per day)				
Measuring gate by quartz tester	Use 10-second gate *Set the winding stem with crown at the normal position				
Antimagnetic	≥ 1600 A/m				
Jewels	0 Jewel				

Disassembling procedures Figs. ① → ⑥②

Reassembling procedures Figs. ⑥② → ①

Type of oil

 Moebius A

 Moebius F

Oil quantity mark

 NORMAL QUANTITY

 SUFFICIENT QUANTITY

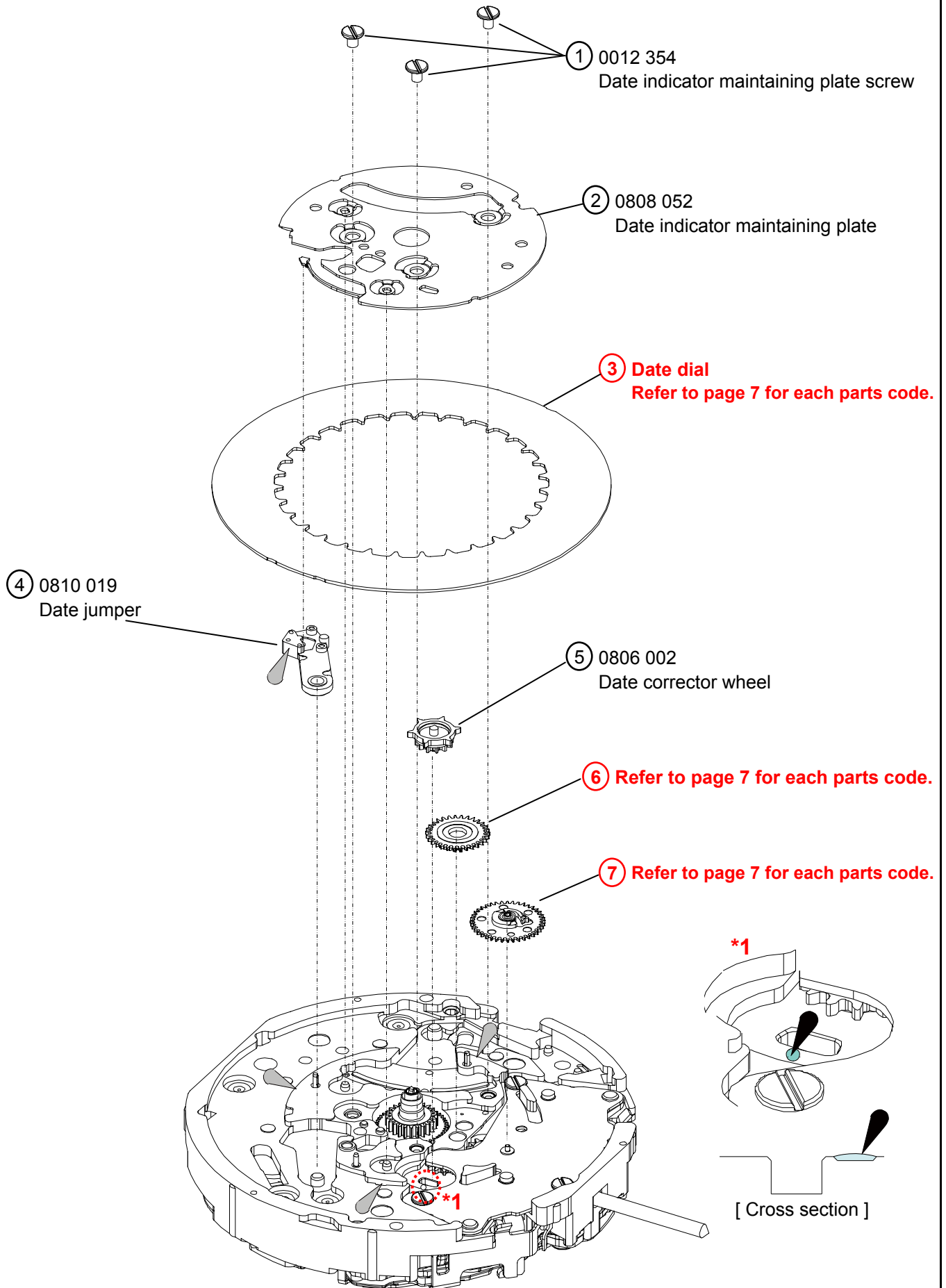

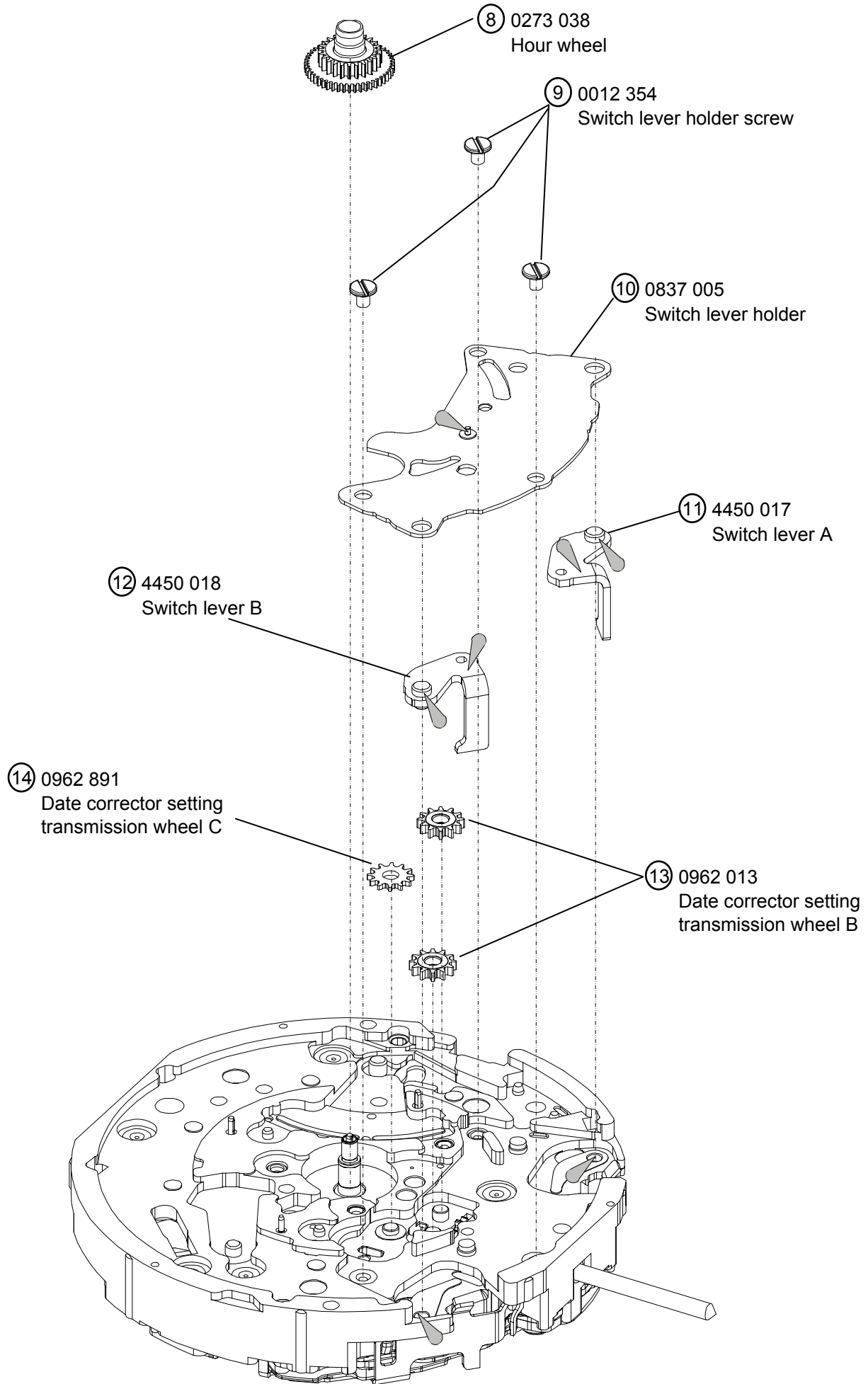

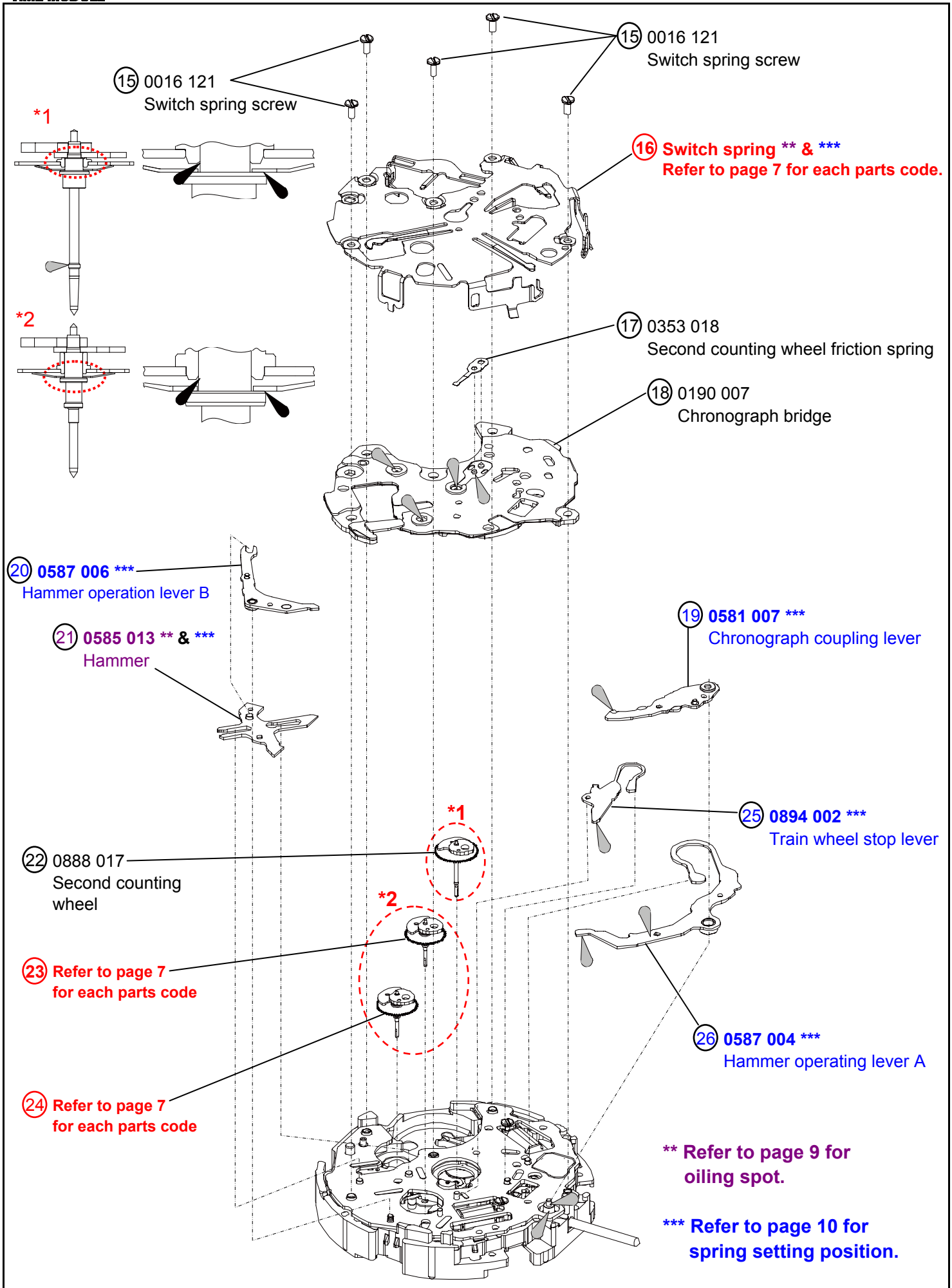

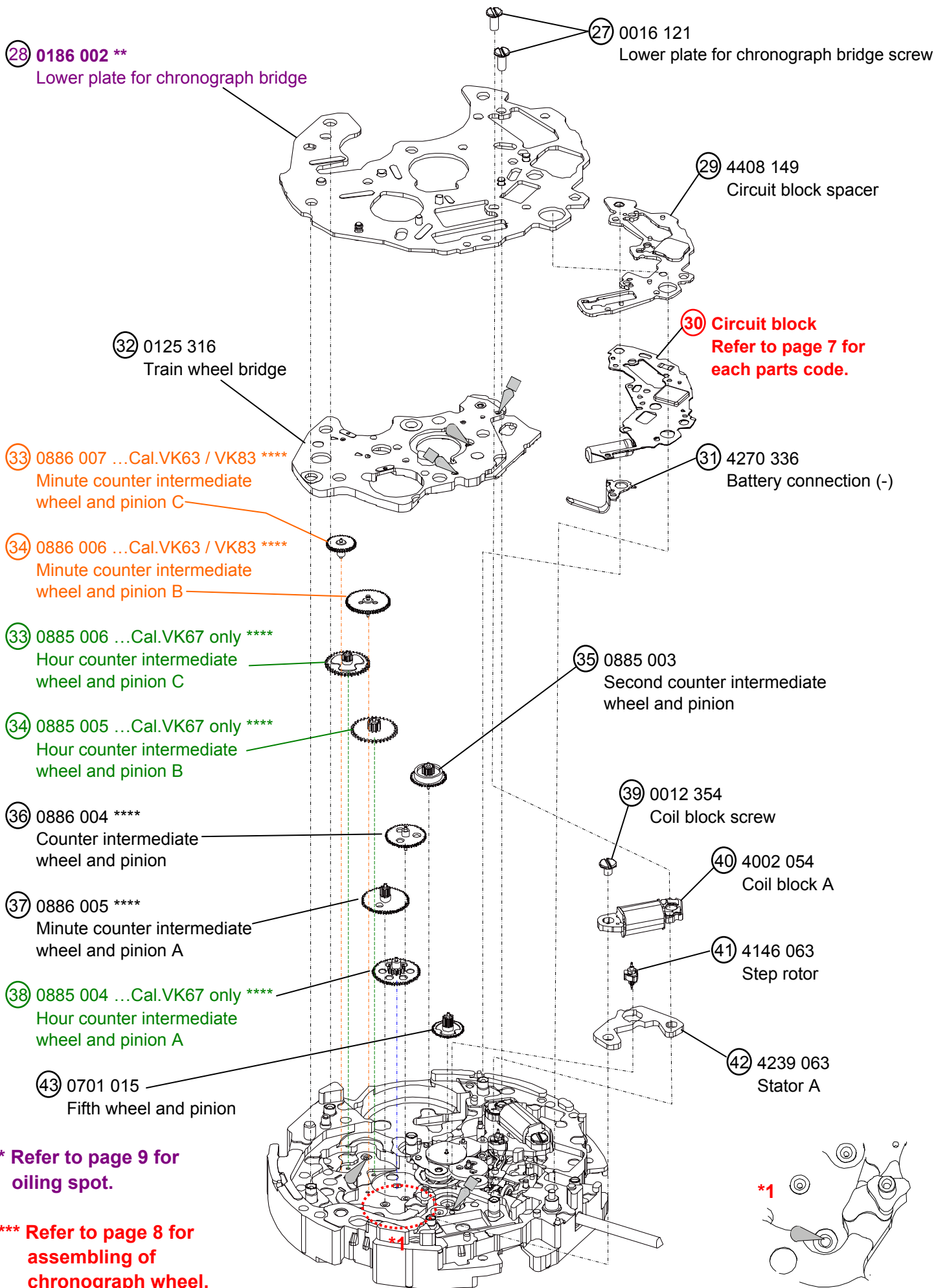

** Refer to page 9 for oiling spot.

**** Refer to page 8 for assembling of chronograph wheel.

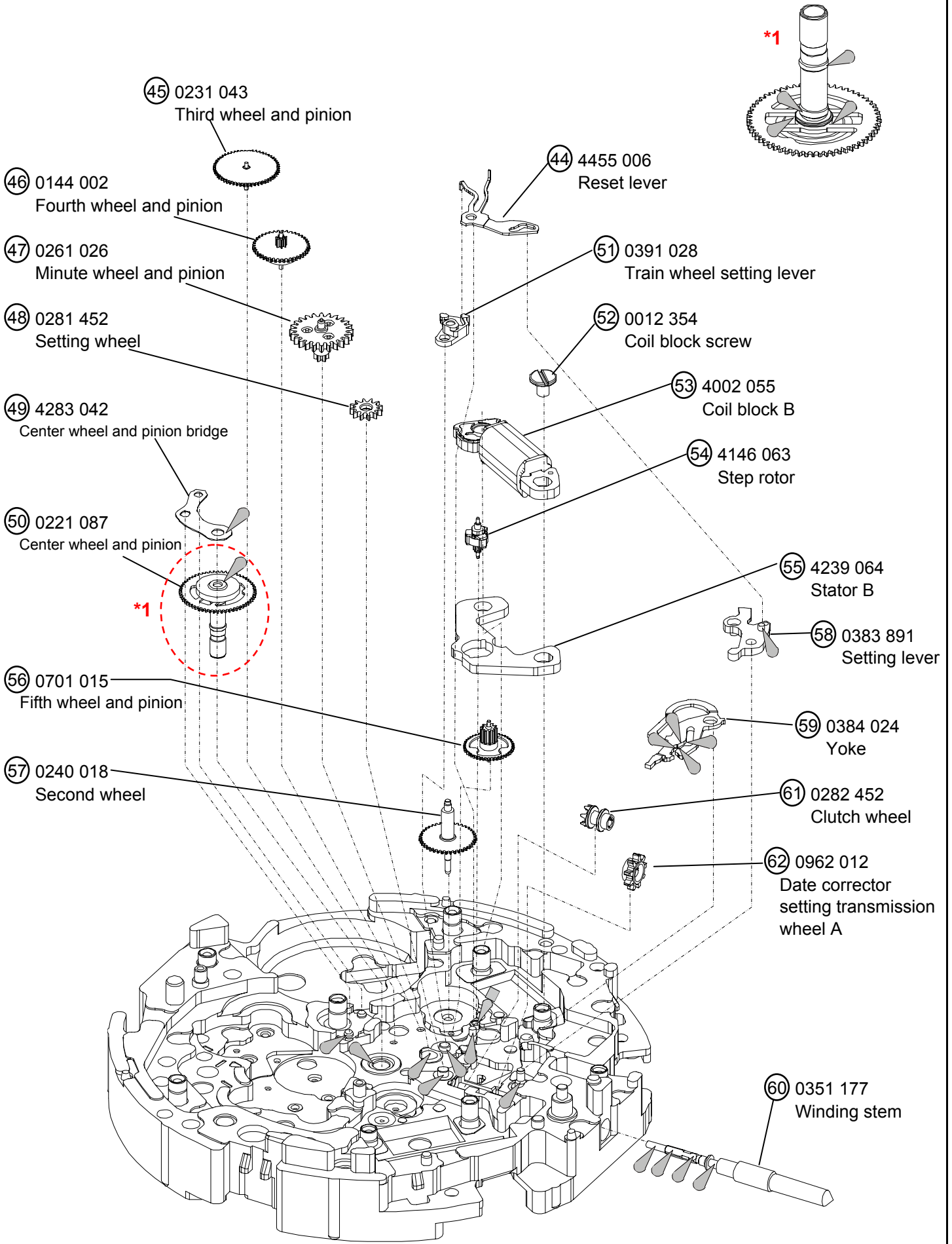

Remarks: **Different parts for each CAL.**

No	Cal.			Parts code	Parts name	Parts form
	VK63	VK67	VK83			
⑥	○	-	○	0817 048	Intermediate small hour hand wheel and pinion	
	-	○	-		Intermediate date wheel and pinion	
⑦	○	-	○	0157 012	Small hour hand wheel	
	-	○	-	0802 039	Date indicator driving wheel	
⑯	○	-	-	4250 035	Switch spring (Differs by Cal. marking)	
	-	○	-	4250 034		
	-	-	○	4250 047		
⑳	○	-	○	0685 002	Positioning arbor	
	-	○	-	0902 011	Minute counting wheel	
㉑	○	-	○	0740 002	Minute counting wheel	
	-	○	-		Hour counting wheel	
㉓	○	-	-	4004 253	Circuit block	
	-	○	-	4004 252		
	-	-	○	4004 277		

[NOTE]

How to distinguish between "Parts code: 0902-011 and 0740-002"

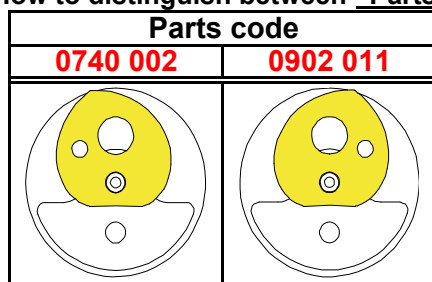

Confirm shape difference to distinguish each parts.

③ Date dial ...Cal.VK63 / 67/ 83 common parts

Parts code	Crown position	Date position	Color of figure	Color of background
0878 328	3H	3H (4.5H)	Black	White

1. Detailed assembling of chronograph wheel

[NOTE]

There is a mark on parts. Parts are set in order of the mark as shown in the table below.

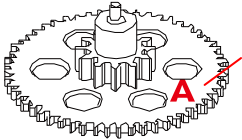
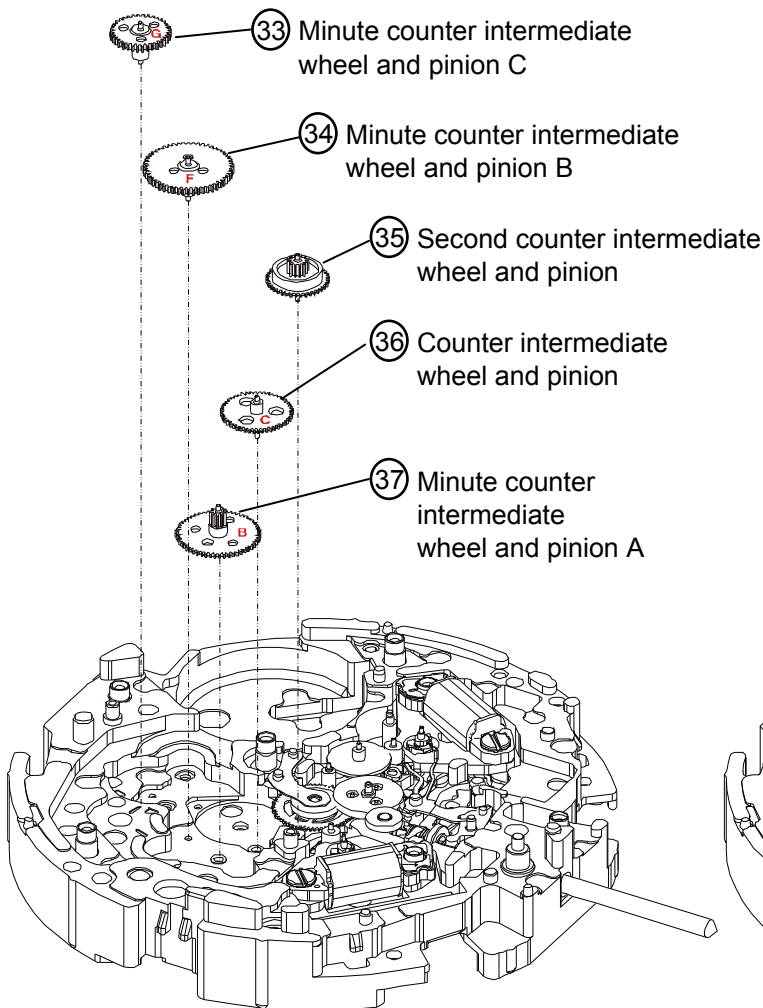

Image example of the mark

[Cal.VK63 and VK83]	
Mark	Parts name
B	③⑦ Minute counter intermediate wheel and pinion A
C	③⑥ Counter intermediate wheel and pinion
Nil	③⑤ Second counter intermediate wheel and pinion
F	③④ Minute counter intermediate wheel and pinion B
G	③③ Minute counter intermediate wheel and pinion C

[Cal.VK67]	
Mark	Parts name
A	③⑧ Hour counter intermediate wheel and pinion A
B	③⑦ Minute counter intermediate wheel and pinion A
C	③⑥ Counter intermediate wheel and pinion
Nil	③⑤ Second counter intermediate wheel and pinion
D	③④ Hour counter intermediate wheel and pinion B
E	③③ Hour counter intermediate wheel and pinion C



[Cal.VK63 and VK83]

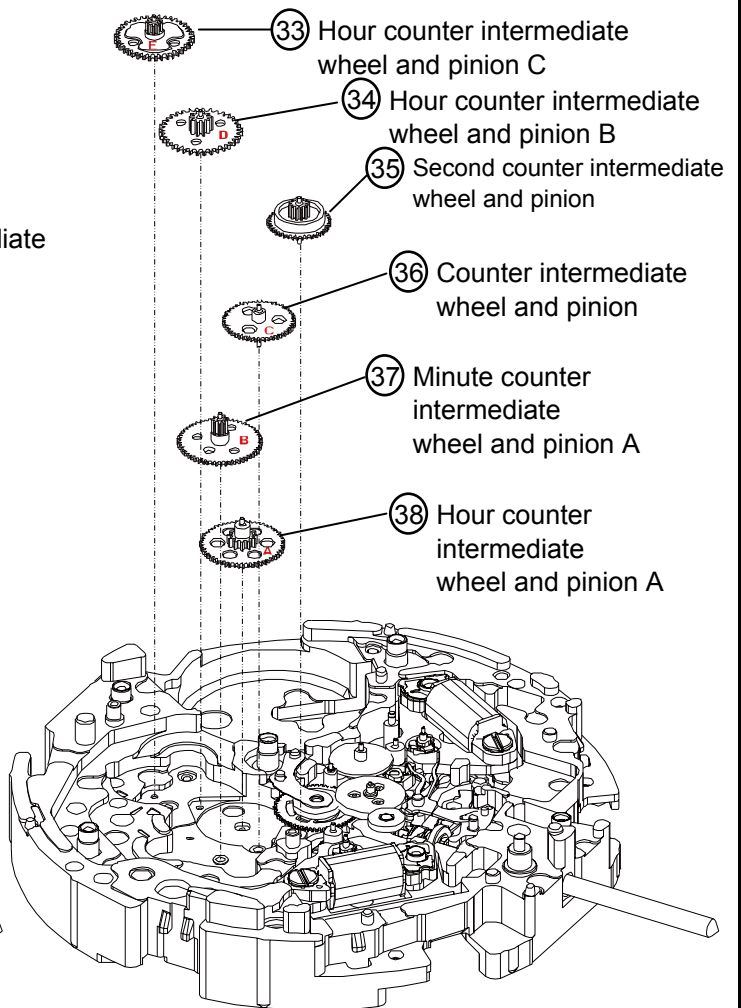

[Cal.VK67]



*Mark positions, and sizes, etc. are different.

Type of oil	Oil quantity mark
 Moebius A	 NORMAL QUANTITY
	 SUFFICIENT QUANTITY

2. Oiling spot
⑳ Hammer

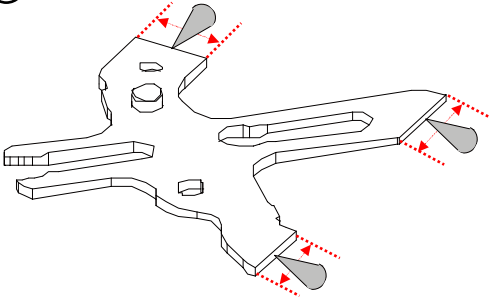

There must be oil within the range of the arrow.

㉔ Lower plate for chronograph bridge

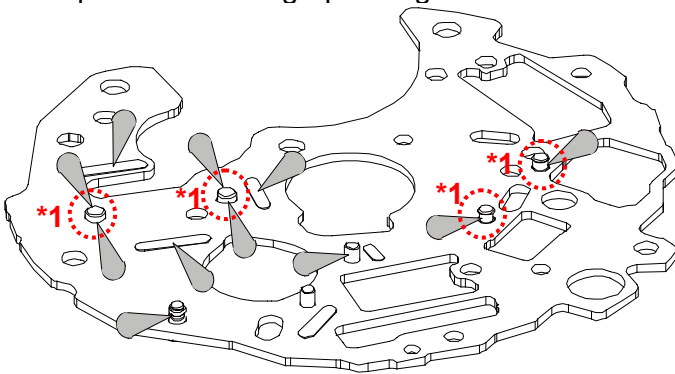

Note
***1:** Oiling should be done on the pointed spot of marked place.

⑯ Switch spring
*Oiling spot and spring setting position.

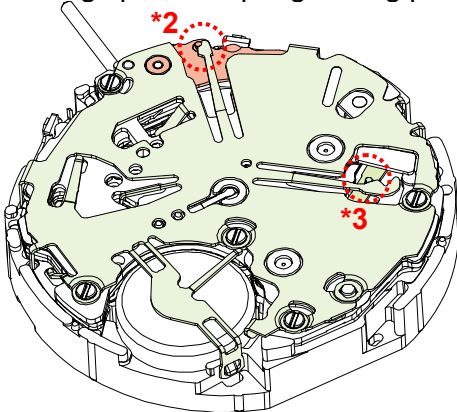

⑲ Chronograph coupling lever

㉓ Hammer operation lever B

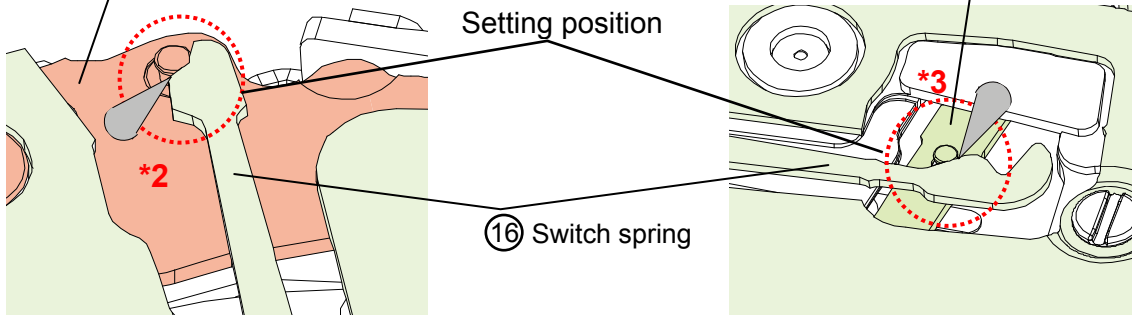

*Oiling should be done on the contact spot of the spring and the pin.

3.Spring setting position

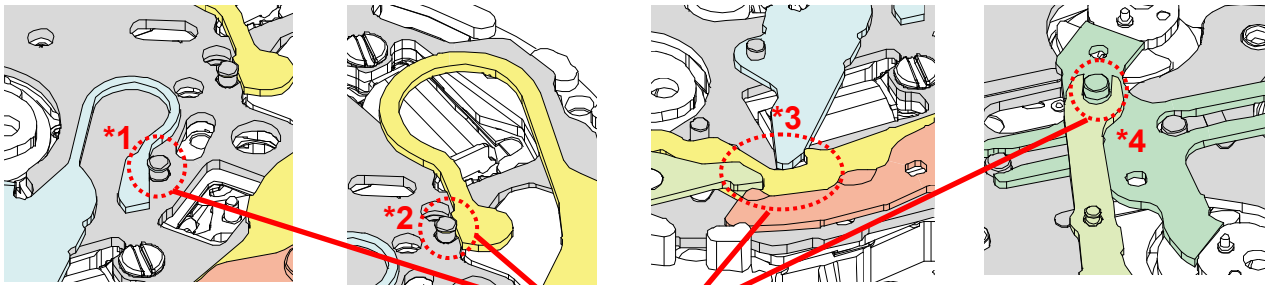
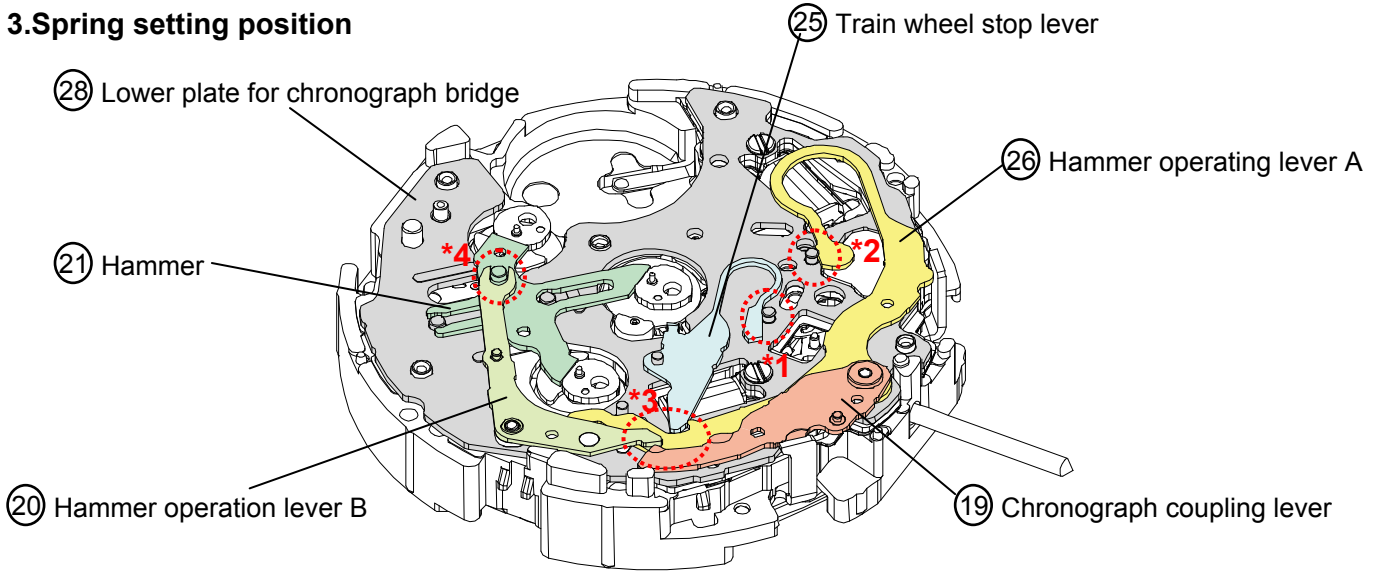

Setting position

4.Switch lever A and B setting position

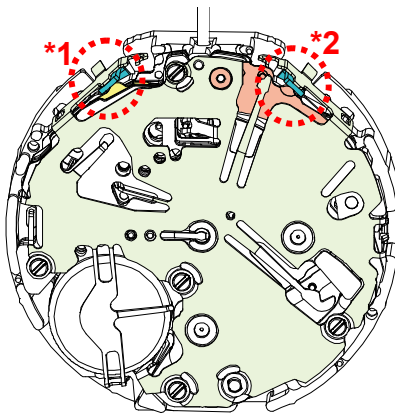

Enlarged view

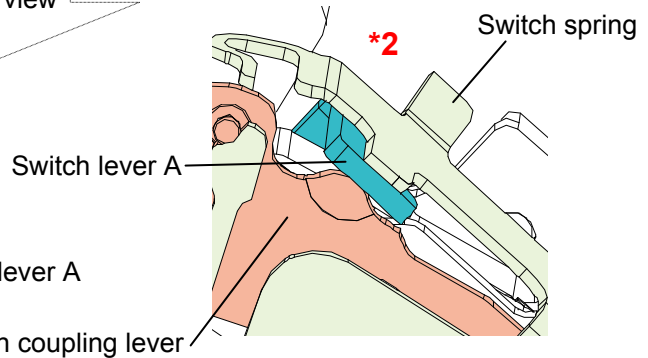
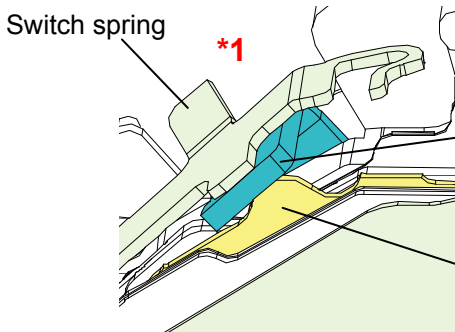

Switch lever B is set between the switch spring and hammer operation lever A .

Switch lever A is set between the switch spring and chronograph coupling lever.

5.To remove the winding stem

- 1) Set the winding stem to normal position.
- 2) Pull out the winding stem while pushing "A".

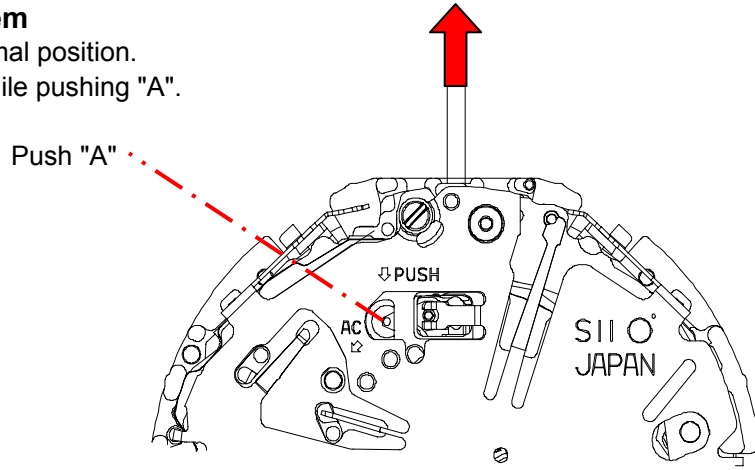

6.To remove or install the battery

- 1) Remove the hook of the switch spring's battery clamp.
- 2) Insert the battery sideways, and have the hook of the switch spring's battery clamp catch the main plate.

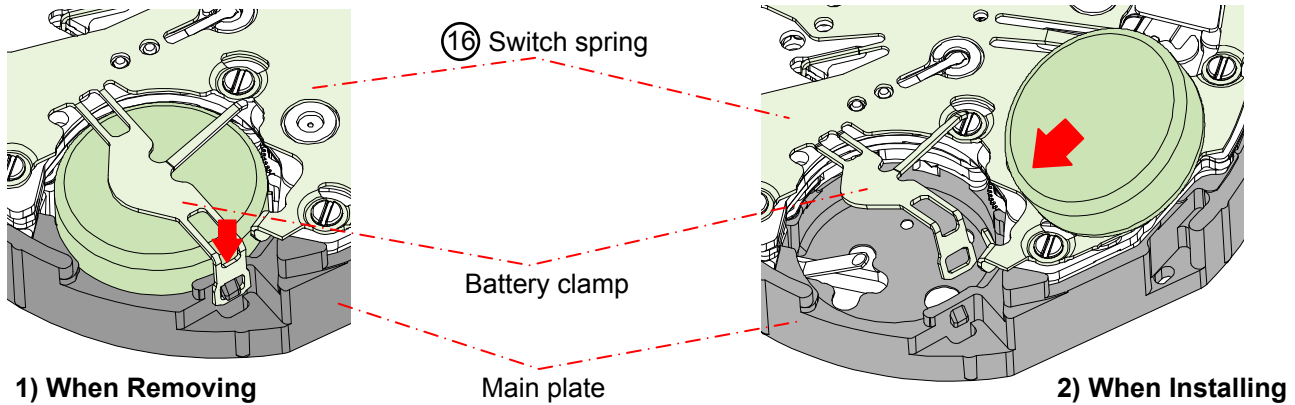

7.Remarks on installing the battery

- 1) After the battery is replaced with a new one, or after the battery is reinstalled following the repairing procedures, be sure to touch the AC terminal of circuit block and the switch spring with conductive tweezers to reset the circuit as illustrated.

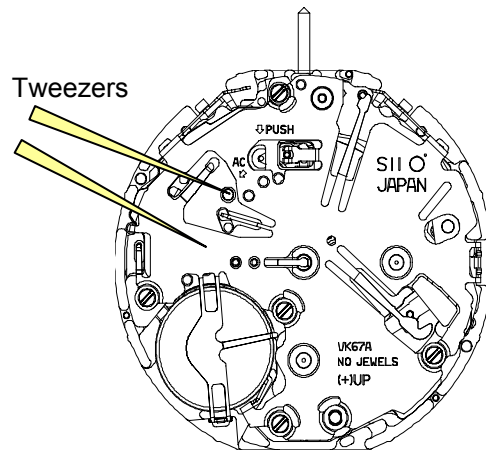

8.How to attach hands

Place the movement directly on a flat metal plate, or something alike to install the hands.

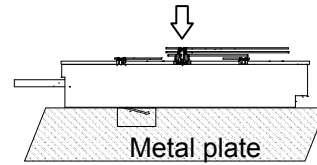

[Note: Second / Minute / Hour chronograph hands setting]

- (1) Push button A (Chronograph start)
- (2) Push button A (Chronograph stop)
- (3) Push button B (Chronograph reset)
- (4) After (1)-(3), Install the chronograph hands as shown in the table below.

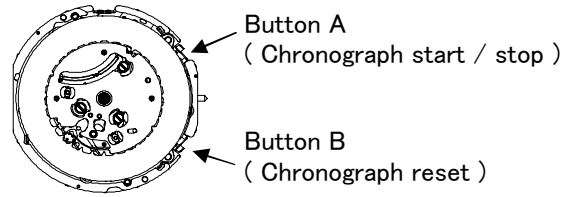

Cal.	VK63	VK67	VK83
Second chronograph	"12" o'clock (center)	"12" o'clock (center)	"12" o'clock (center)
Minute chronograph	"60" minute (9H)	"60" minute (12H)	"0" minute (9H)
Hour chronograph	—	"12" hour (9H)	—

***Do not reuse the chronograph hands once detached. Please change and use new hands.**

[Note: To install 24 hour hand for VK63 and VK83]

Before installing 24 hour hand, pull out the crown to the second click position and rotate it clockwise, until changed to the next date then install the 24 hour hand.

9.How to check correct hands attachment

The hand's top surface should be set parallel with the axis tip , as shown below.

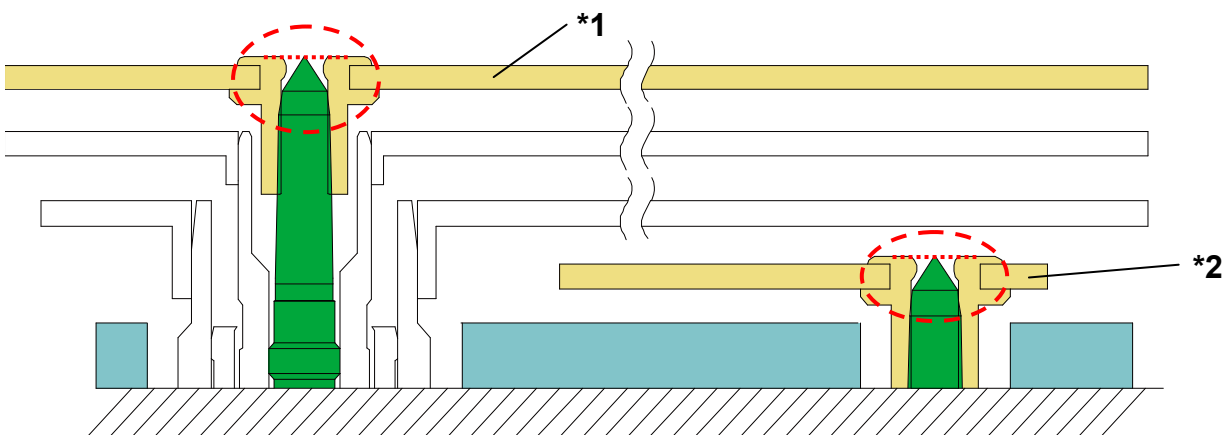

Application hands

- *1: Second chronograph hand
- *2: Minute / Hour chronograph hands and Small second hand and 24 hour hand

DISPLAY AND CROWN / BUTTON OPERATION

<< VK63 >>

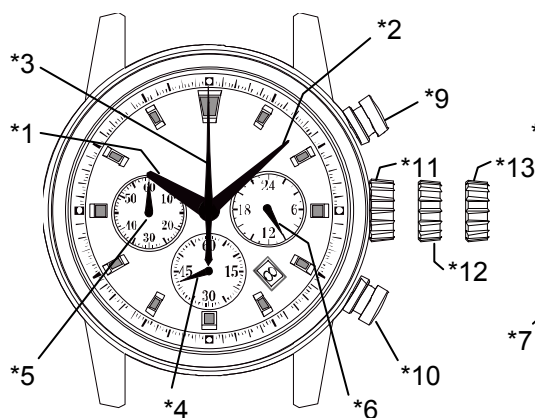

<< VK67 >>

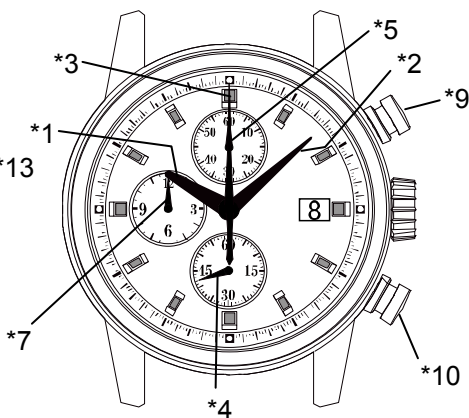

<< VK83 >>

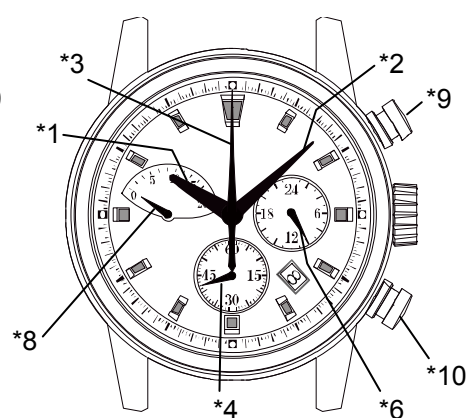
Note

*1: Hour hand	*6: 24 hour hand	*10: Button B (RESET)
*2: Minute hand	*7: Chronograph hour hand (12 hour)	*11: Crown at normal position
*3: Chronograph second hand	*8: Chronograph minute hand (20 minute)	*12: Crown at first position (Date setting)
*4: Small second hand	*9: Button A (START / STOP)	*13: Crown at second position (Time setting)
*5: Chronograph minute hand (60 minute)		

1. How to set the time

- 1) Pull out the crown to the second click position.
- 2) Turn the crown to set hour and minute hands.
(Check that AM / PM is set correctly.)
- 3) Push the crown back into the normal position.

[Note]

If the crown is pulled to the second position while the chronograph is started, the chronograph hands will continue to move. This is not a malfunction.

2. How to set the date

- 1) Pull out the crown to the first click position.
- 2) Turn the crown clockwise for date setting.
*Do not set the date between 9:00 P.M. and 3:00 A.M. as this will cause a malfunction.
- 3) Push the crown back into the normal position.

3. How to reset (after battery change)

It is possible to reset by the following two methods.

- | | | |
|---|----------|--|
| { | Method 1 | 1) Set the crown to the normal position. |
| | | 2) Touch the AC terminal of circuit block and the switch spring with conductive tweezers to reset the circuit. |
| | | 3) The small second hand will move at two-second interval for 10 seconds. |
| { | Method 2 | 1) Pull out the crown to the second click position. |
| | | 2) Press the button B for two seconds and release the button. |
| | | 3) Push the crown back to the normal position. |
| | | 4) The small second hand will move at two-second interval for 10 seconds. |

* If the crown is operated within this 10 seconds, the two-second interval movement will not activate.

[Note]

It is not necessary to set the chronograph hands after the battery is exchanged.

If the chronograph hands position are incorrect, following below procedure all the chronograph hands will be reset to "0" position.



HOW TO USE THE CHRONOGRAPH

[Standard measurement]

Press the buttons in the following order : A → A → B

START

STOP (Finish)

reset

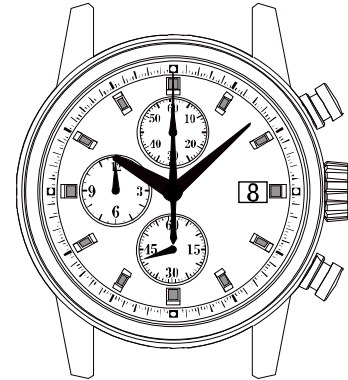
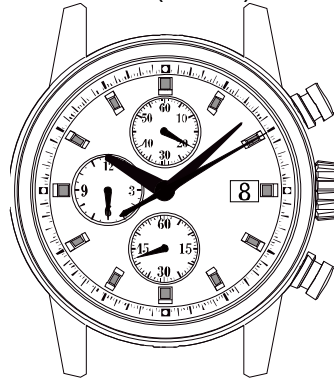

(6 hour 20 minutes 10 seconds)

• Press button A to start the chronograph.
The chronograph second hand will start moving.

• Press button A again to stop the chronograph.
The chronograph hands stop to indicate the elapsed time.

• Press button B to reset the chronograph.
All the chronograph hands will be reset to "0" position.

Note

[Cal.VK63]

The chronograph can measure up to 60 minutes.
The chronograph stops after a measurement for 60 minutes.

[Cal.VK67]

The chronograph can measure up to 12 hours.
The chronograph stops after a measurement for 12 hours.

*** Restart by pushing button A. ... Cal.VK63 and VK67**

[Cal.VK83]

The chronograph can measure up to 20 minutes.
The chronograph stops after a measurement for 20 minutes.

*** Restart in the following procedure.**



[Cal.VK63 / 67/ 83 in common]

* During the chronograph operation, button B (reset) can be pushed. There is no problem with the function.

[Accumulated elapsed time measurement]

Press the buttons in the following order : A → A / A ... → A → B

START

STOP / RESTART

STOP

RESET

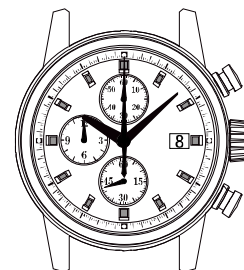
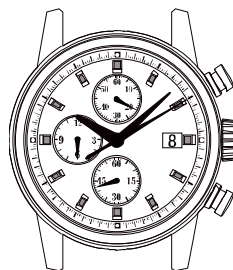
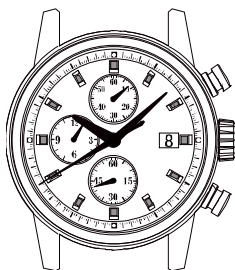
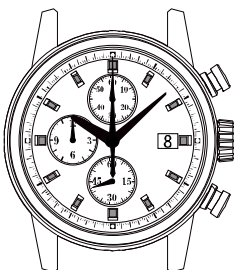

(1 hour 8 minute 40 seconds) (6 hour 20 minutes 10 seconds)

* Restart and stop of the chronograph can be repeated as many times as necessary by pressing button A